

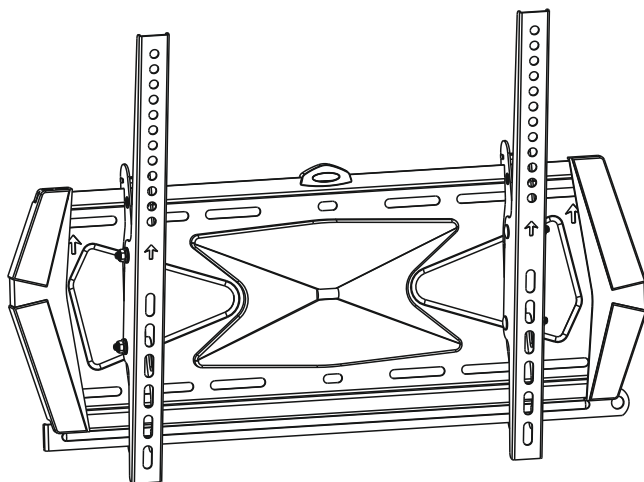

UCH0142

Full Motion LED, LCD TV Wall Mount



User manual



300x300/400x200
400x400



English 1-10

Polski 11-20

Română 21-30

Deutsch 31-40

NOTE: Read entire instruction sheet before you start installation and assembly.

WARNING

- Do not begin to installation of the product on you have read and understand the instructions and warnings contained in this Installation Sheet. If you have any question regarding any of the instruction or warning, Please contact your local distributor.
- Please refer to manufacturer's installation guide recommendation for required distance from wall to avoid risk of property damage.
- This product should only be installed by someone of good mechanical aptitude, with experience and basic building, and fully understands.
- Make sure that the supporting surface will safely support the combined load of the equipment and all attached hardware and components.
- Never exceed the Maximum Load Capacity.
- If mounting to wood wall studs, make sure that mounting screws are anchored into the center of the studs. Use of an "edge to edge" stud finder is highly recommended.
- Always use an assistant or mechanical lifting equipment to safely lift and position equipment.
- Tighten screws firmly, but do not over tighten. Over tightening can damage the items, greatly reducing their holding power.
- This products intended for indoor use only. Use of this product outdoors could lead to product failure and personal injury.

Component checklist

IMPORTANT: Ensure you have received all parts against the component checklist prior to installing. If any parts are missing or faulty, telephone the special franchiser for a placement.

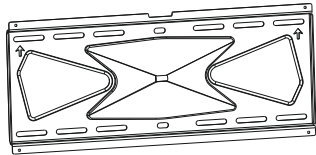

wall mount(x1)
A



safety bar(x1)
B

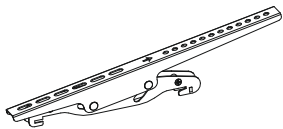

left adapter bracket(x1)
C

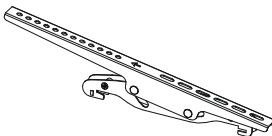

right adapter bracket(x1)
D



bubble level(x1)
E



decorative cover(x2)
F



ST2.9*6.5(x4)
G

Package M



M5x14 (x4)
M-A

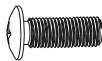

M6x14 (x4)
M-B

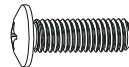

M8x20 (x4)
M-C



M6x30 (x4)
M-D



M8x30 (x4)
M-E



washer (x4)
M-F



small spacer (x8)
M-G



big spacer (x4)
M-H

Package W

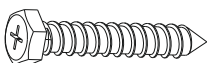

ST6.3x55 (x4)
W-A



concrete anchor (x4)
W-B



D6 washer (x4)
W-C

1. Install Decorative Covers

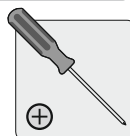
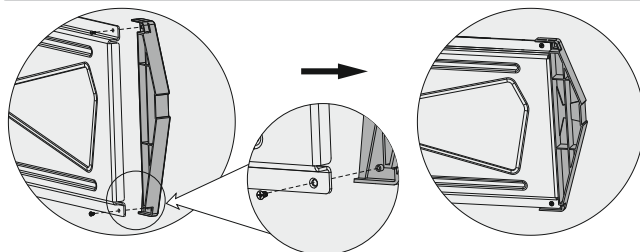

Attach decorative covers to wall plate using screws.

Note: With the gap of the decorative cover downward.

2a. Mount on Wood Stud Wall

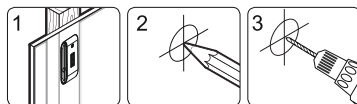
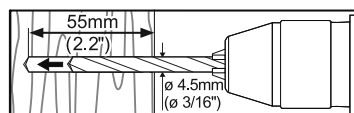

Find and mark the exact location of mounting holes **Drill pilot holes**

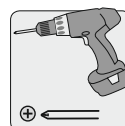
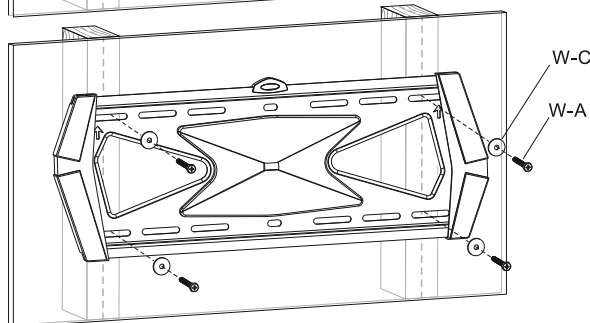
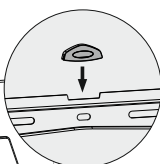
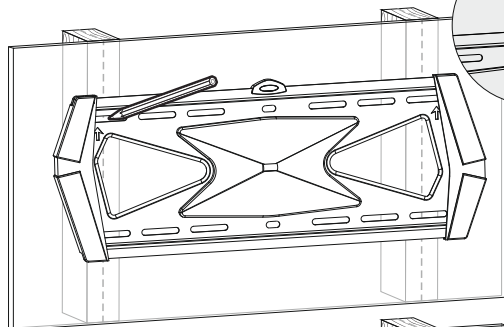
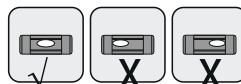

Screw the wall plate onto the wall

with the up arrow of the plate upward

⚠ WARNING

- Make sure that mounting screws are anchored into the center of the studs. Use of a stud finder is highly recommended.
- Installers are responsible to provide hardware for other types of mounting situations.
- Installers must verify that the supporting surface will safely support the combined load of the equipment and all attached hardware and components.

2b. Mount on Solid Brick and Concrete Block

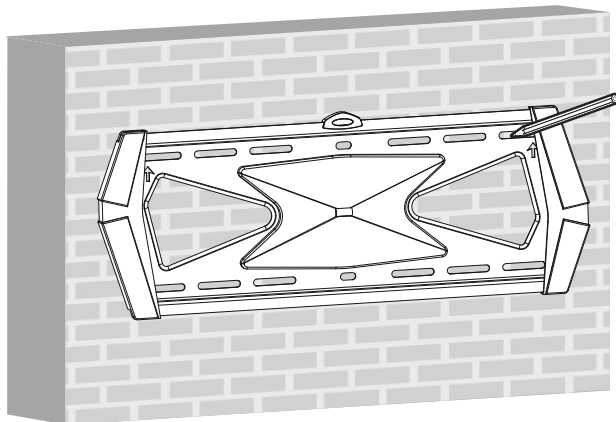
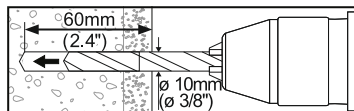

1
Mark the exact location of mounting holes

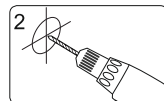

2
Drill pilot holes

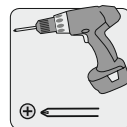
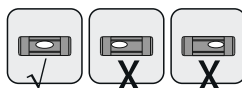
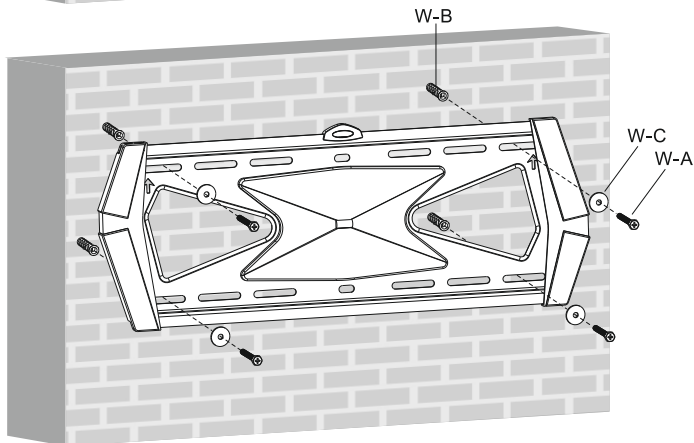

Screw the wall plate onto the wall

with the up arrow of the plate upward

WARNING

- When installing wall mounts on cinder block, verify the actual concrete thickness is at least 1-3/8" (35mm) for using the concrete anchors. Do not drill into mortar joints! Be sure to mount in a solid part of the block, generally 1" (25mm) minimum from the side of the block. It is suggested electric drill on slow setting is used to drill the hole instead of a hammer drill to avoid breaking out the back of the hole when entering a void or cavity.
- Installers must verify that the supporting surface will safely support the combined load of the equipment and all attached hardware and components.

3. Install Adapter Brackets

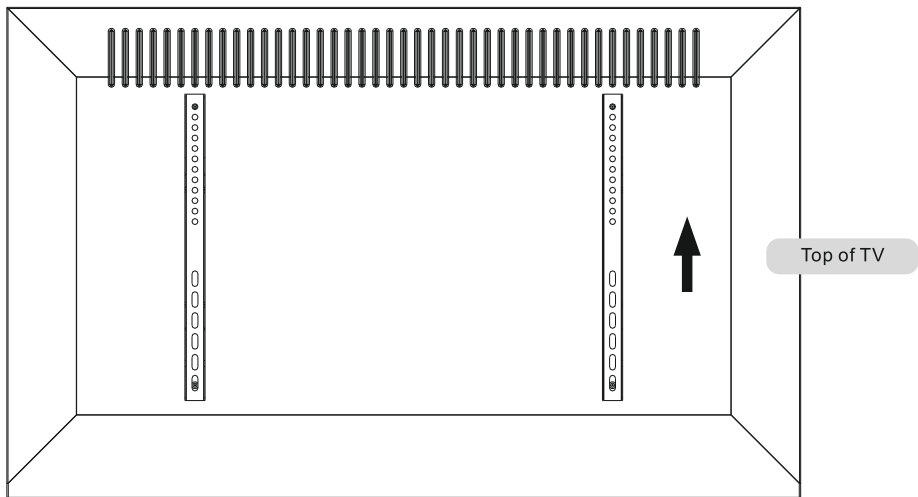

3-1 For Flat Back Screen

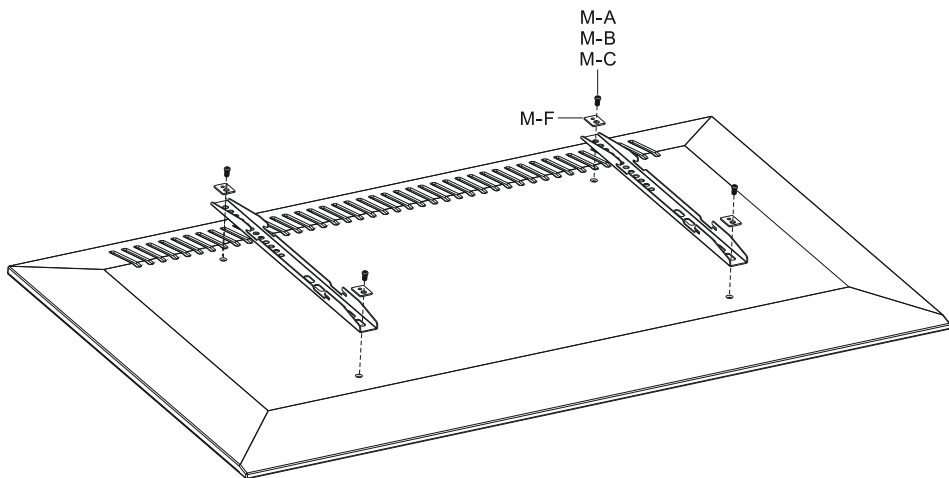

3-2 For Recessed Back Screen or to Access A/V Inputs

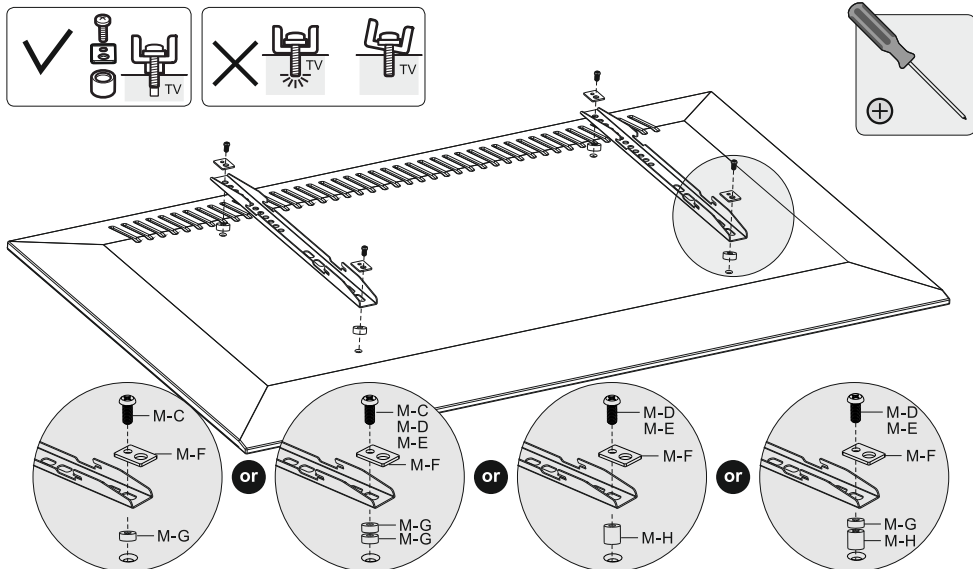

Note: Choose appropriate screws, washers and spacers (if necessary) according to the type of screen.

- Position the adapter brackets as close as possible to the center of the display.
- Screw the adapter brackets onto the display.

 **Tighten all screws but do not over tighten.**

4. Hook the TV onto the Wall Mount

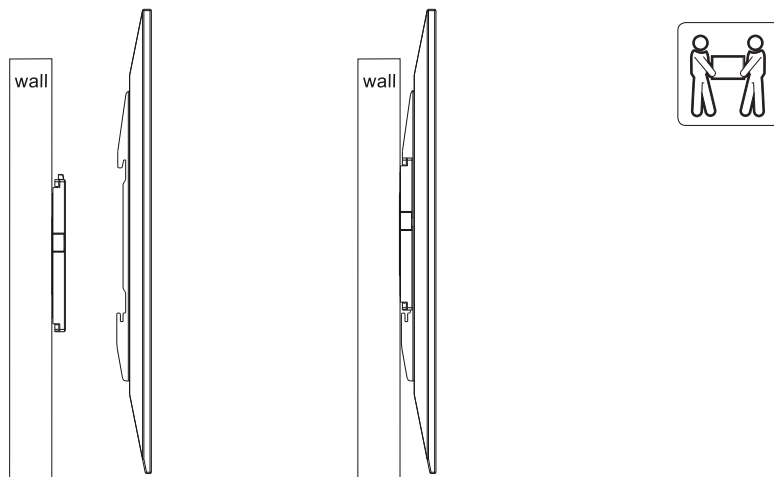

Hook the TV over the top of the wall plate.

Important: Make sure the TV is correctly hooked before releasing the TV.

5. Safety bar

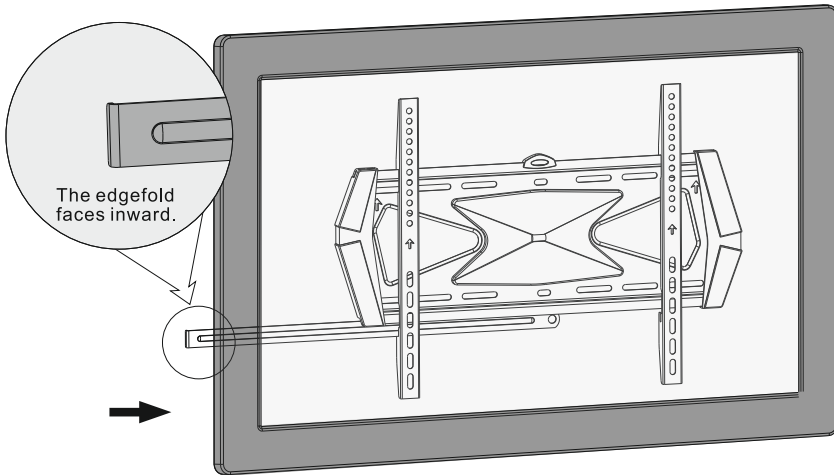

Insert the safety bar to secure the rails.

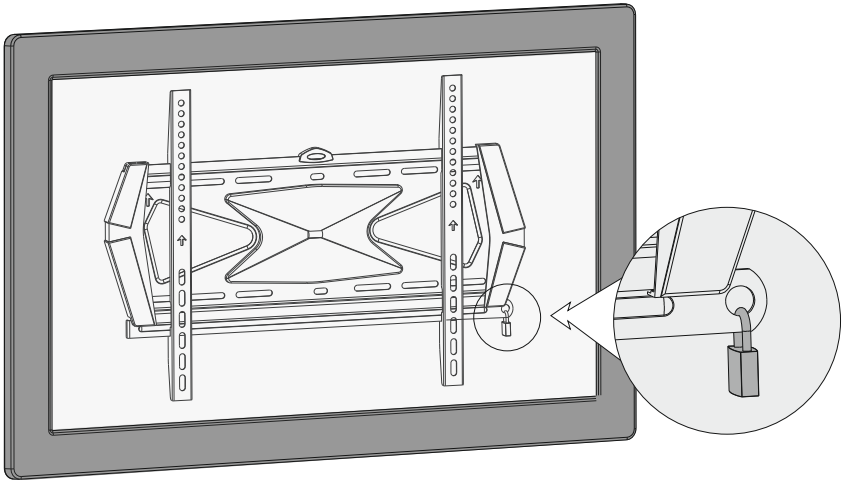

Use the padlock to prevent TV from stealing. (The padlock is not included)

5. Adjustment

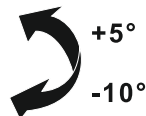
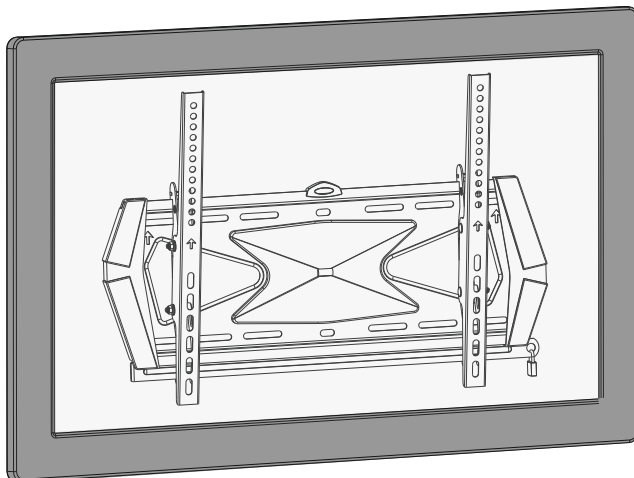

Maintenance

Maintenance

- Check that the bracket is secure and safe to use at regular intervals(at least every three months).
- Please contact your dealer if you have any questions.

English



Correct Disposal of This Product (Waste Electrical & Electronic Equipment)

(Applicable in the European Union and other European countries with separate collection systems)

This marking shown on the product or its literature, indicates that it should not be disposed with other household wastes at the end of its working life. To prevent possible harm to the environment or human health from uncontrolled waste disposal, please separate this from other types of wastes and recycle it responsibly to promote the sustainable reuse of material resources.

Household users should contact either the retailer where they purchased this product, or their local government office, for details of where and how they can take this item for environmentally safe recycling.

Business users should contact their supplier and check the terms and conditions of the purchase contract. This product should not be mixed with other commercial wastes for disposal.



Made in China for LECHPOL Zbigniew Leszek, Miętne, 1 Garwolińska Street 08-400 Garwolin.



UCH0142

Regulowany uchwyt ścienny do TV

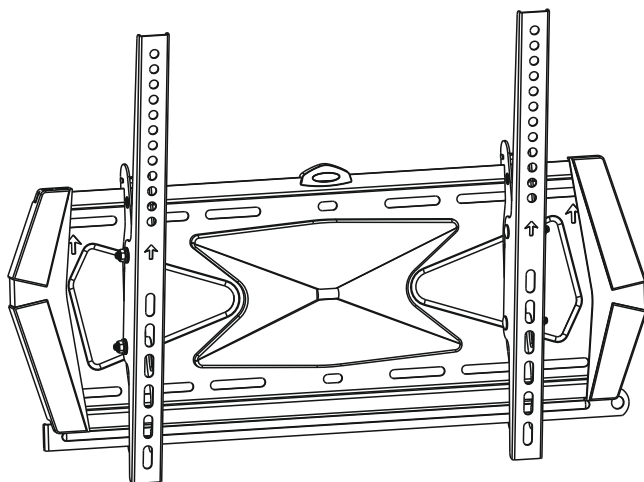

Instrukcja obsługi



300x300/400x200
400x400



English 1-10

Polski 11-20

Română 21-30

Deutsch 31-40

UWAGA: Przed rozpoczęciem montażu, należy przeczytać instrukcję obsługi.

UWAGA

- Przed przystąpieniem do instalacji należy dokładnie przeczytać całą instrukcję. W przypadku jakichkolwiek wątpliwości należy się skontaktować z lokalnym dystrybutorem.
- Należy przestrzegać zaleceń producenta odnośnie miejsca i sposobu montażu.
- Instalacja produktu powinna być przeprowadzona przez wykwalifikowaną osobę cechującą się dobrymi umiejętnościami mechanicznymi, znającą konstrukcję budynku oraz dobrze rozumiejącą instrukcję obsługi.
- Przed przystąpieniem do montażu, należy się upewnić, że powierzchnia nośna wytrzyma obciążenie uchwytu wraz z podłączonymi do niego urządzeniami.
- Nigdy nie należy przekraczać dopuszczalnego maksymalnego obciążenia.
- Podczas przymocowywania telewizora należy skorzystać z pomocy drugiej osoby.
- Śruby należy dokręcić mocno, lecz nie za mocno. Zbyt mocne dokręcenie może doprowadzić do ich zniszczenia lub osłabienia.
- Produkt przeznaczony jest do użytku wewnątrz pomieszczeń. Korzystanie z tego produktu na zewnątrz może doprowadzić do jego uszkodzenia oraz innych zniszczeń.

Lista komponentów

WAŻNE: Należy się upewnić, że w zestawie są wszystkie elementy wymienione na liście. Jeżeli brakuje jakiegokolwiek części lub jest ona uszkodzona, należy skontaktować się z dystrybutorem.

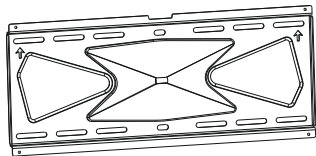

uchwyt ścienny (x1)
A



listwa zabezpieczająca (x1)
B

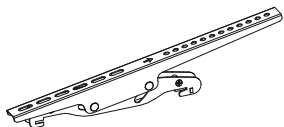

lewy wspornik (x1)
C

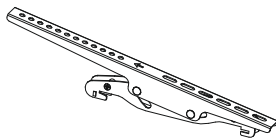

prawy wspornik (x1)
D



poziomica (x1)
E



osłona dekoracyjna (x2)
F



ST2.9*6.5(x4)
G

Opakowanie M



M5x14 (x4)
M-A

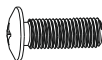

M6x14 (x4)
M-B



M8x20 (x4)
M-C



M6x30 (x4)
M-D



M8x30 (x4)
M-E



podkładka (x4)
M-F



dystans - mały (x8)
M-G



dystans - duży (x4)
M-H

Opakowanie W

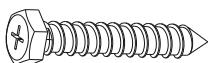

Śruba ST6.3x55 (x4)
W-A



kołek rozporowy (x4)
W-B



D6 podkładka (x4)
W-C

1. Instalacja osłon dekoracyjnych

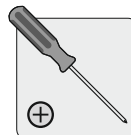
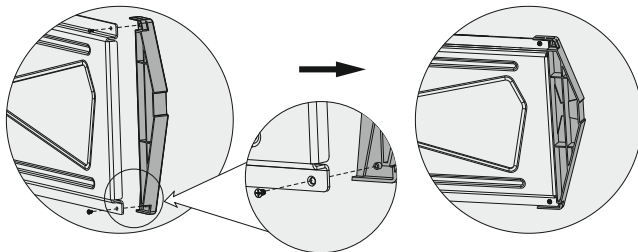

Oslony dekoracyjne należy przymocować za pomocą dołączonych do zestawu śrub.

2a. Montaż do ściany drewnianej

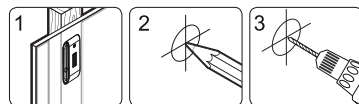
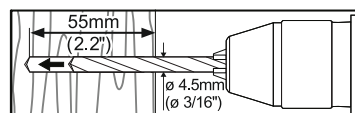

Należy dokładnie zaznaczyć i wywiercić otwory montażowe.

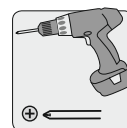
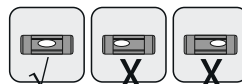
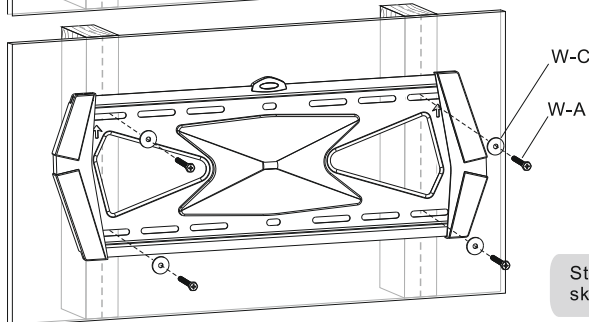
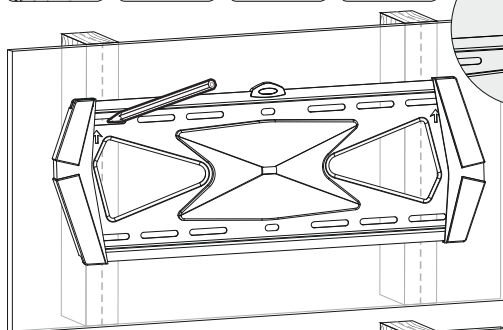

Za pomocą śrub należy przykręcić uchwyt do ściany.

Strzałki na uchwycie powinny być skierowane do góry.

⚠ UWAGA

- Należy się upewnić, że powierzchnia nośna wytrzyma obciążenie uchwytu wraz z podłączonymi urządzeniami.
- Jeżeli wymagany jest inny typ instalacji niż opisany, to instalator odpowiada za dostarczenie potrzebnego sprzętu.
- Śruby należy dokręcić mocno, lecz nie zbyt mocno. Zbyt mocne dokręcenie może doprowadzić do ich zniszczenia lub osłabienia.

2b. Montaż do ściany betonowej

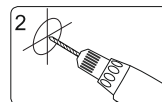
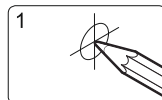
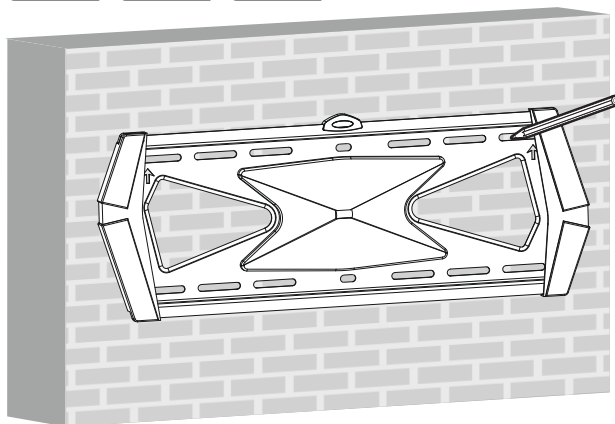
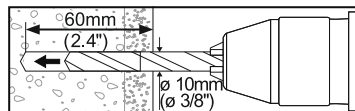

Należy dokładnie zaznaczyć i wywiercić otwory montażowe.

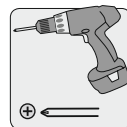
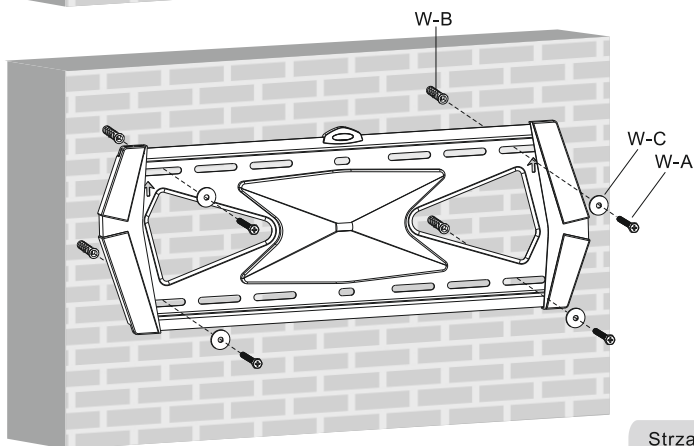
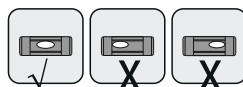

Za pomocą śrub należy przykręcić uchwyt do ściany.

Strzałki na uchwycie powinny być skierowane do góry.

⚠ UWAGA

- Nie należy wiercić otworów w zaprawie murarskiej. Kołki rozporowe należy zamontować w stałej części bloku, przynajmniej 1cm od brzegu. Zalecane jest używanie wiertarki elektrycznej z ustawionymi wolnymi obrotami. Nie jest wskazane używanie wiertarki udarowej.
- Należy się upewnić, że powierzchnia nośna wytrzyma obciążenie uchwytu wraz z podłączonymi do niego urządzeniami.

3. Montaż wsporników

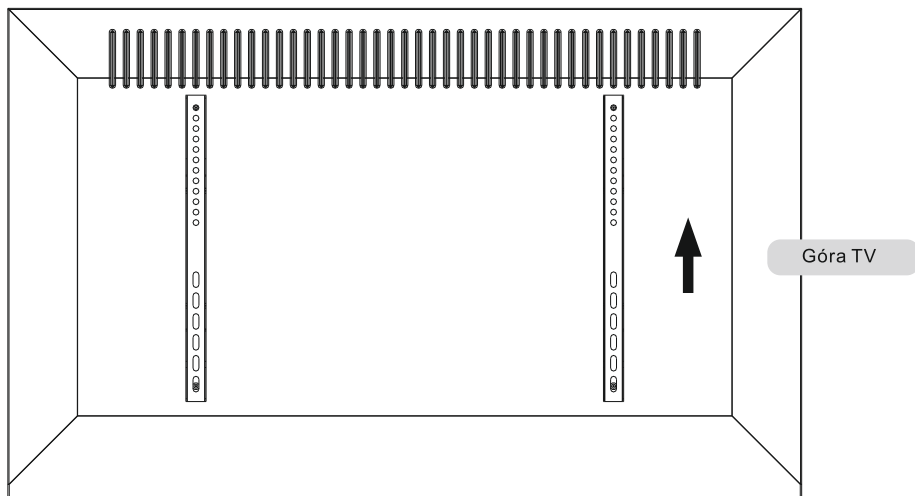

3-1 Telewizor z płaskim tyłem

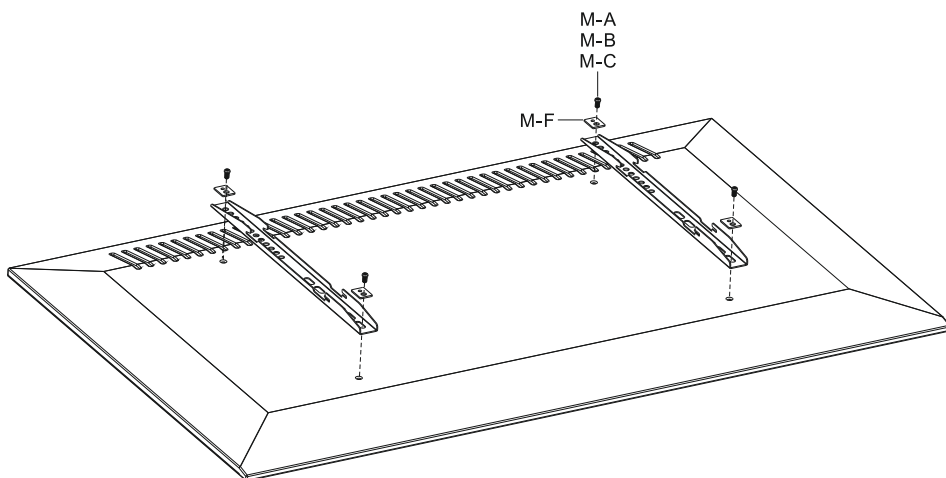
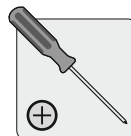

3-2 Telewizor z wypukłym tyłem

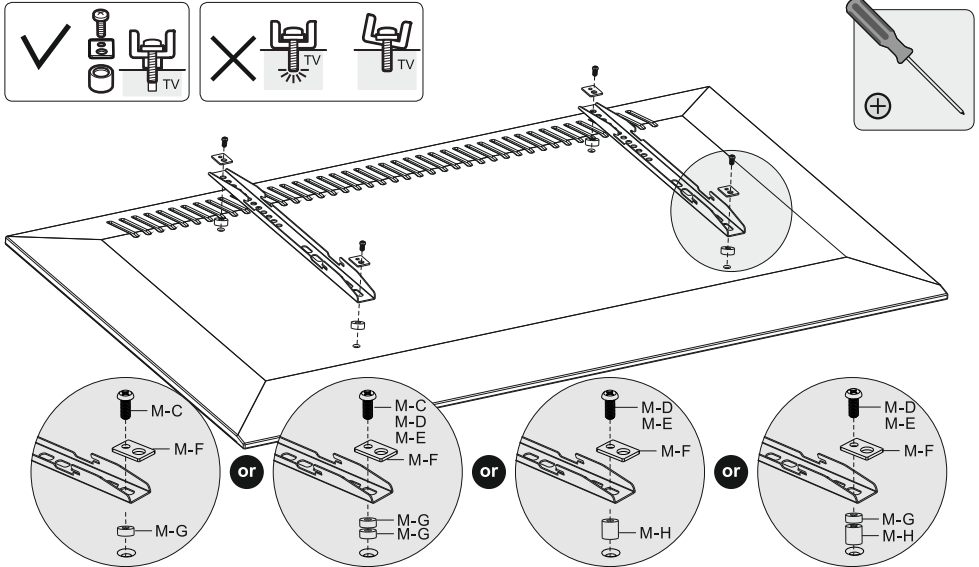

Uwaga: W zależności od typu ekranu należy użyć odpowiednich dystansów, podkładek i śrub.

- Wsporniki należy umieścić jak najbliżej centralnej części ekranu.
- Za pomocą odpowiednich śrub należy przykręcić wsporniki do ekranu.



Śruby należy przykręcić mocno, ale nie zbyt mocno (aby nie zniszczyć gwintu).

4. Przymocowanie telewizora do uchwyty

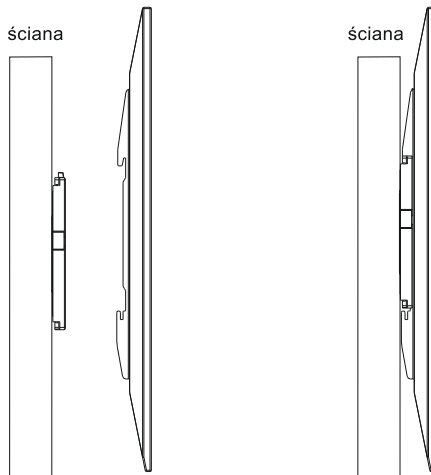

Wsporniki telewizora należy zamocować na zaczepach uchwyty.

Uwaga: Przed puszczeniem telewizora, należy się upewnić, że jest on stabilnie zamocowany.

5. Listwa zabezpieczająca

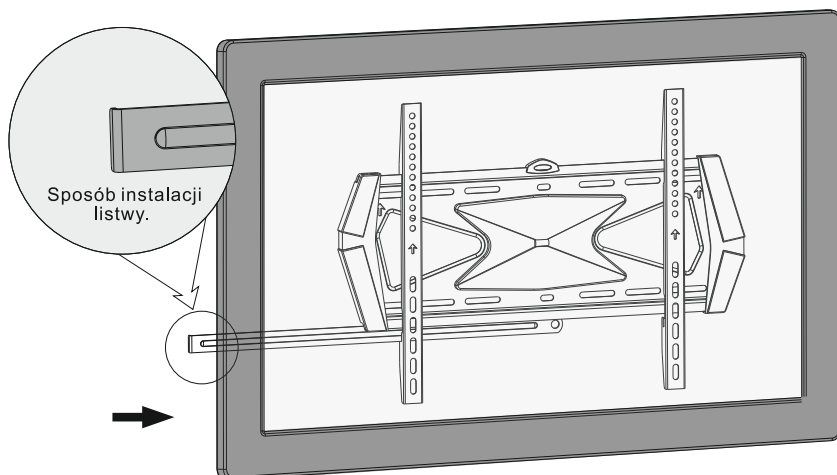

Listwa zabezpiecza zaczepy przed zdjęciem telewizora.

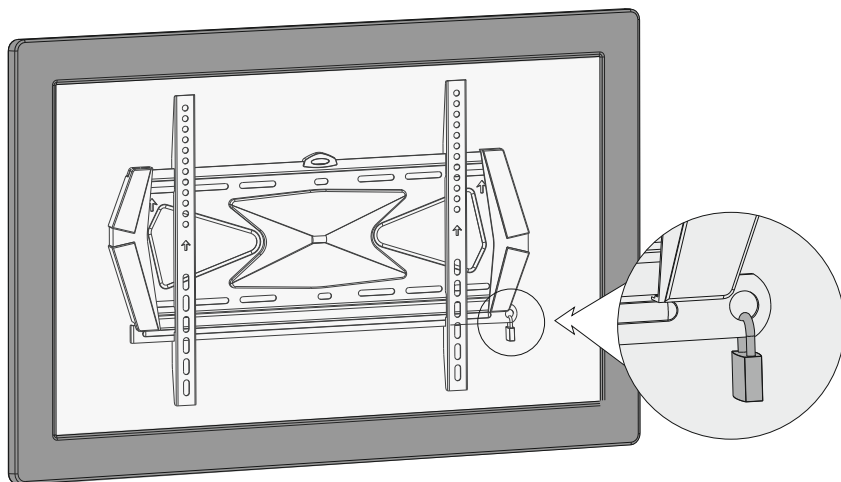

Aby zabezpieczyć telewizor przed kradzieżą, należy zamontować kłódkę na listwie zabezpieczającej (kłódka nie jest dołączona do zestawu).

5. Regulacja kąta pochylenia

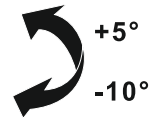
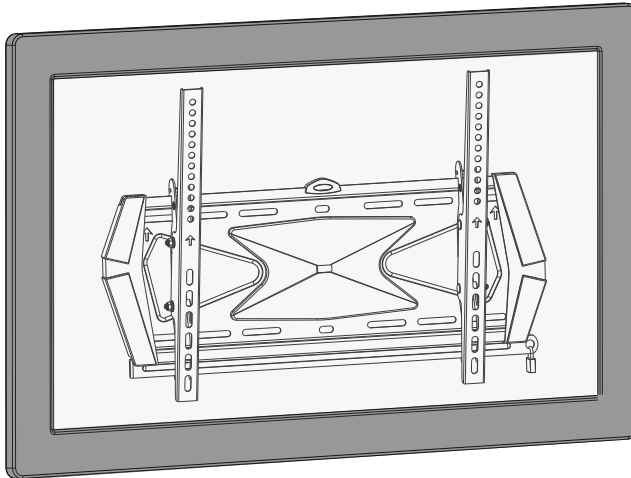

Użytkowanie

- Po zawieszeniu telewizora, należy się upewnić że jest on dobrze przymocowany. Należy okresowo (np. co kilka miesięcy) sprawdzać, czy śruby i inne elementy nie poluzowały się i są solidnie zamocowane.
- Jeżeli istnieją jakiegokolwiek wątpliwości lub problemy odnośnie montażu, należy skontaktować się z lokalnym dystrybutorem.

Poland



Prawidłowe usuwanie produktu (zużyty sprzęt elektryczny i elektroniczny)

Oznaczenie umieszczone na produkcie lub w odnoszących się do niego tekstach wskazuje, że po upływie okresu użytkowania nie należy usuwać z innymi odpadami pochodzącymi z gospodarstw domowych. Aby uniknąć szkodliwego wpływu na środowisko naturalne i zdrowie ludzi wskutek niekontrolowanego usuwania odpadów, prosimy o oddzielenie produktu od innego typu odpadów oraz odpowiedzialny recykling w celu promowania ponownego użycia zasobów materialnych jako stałej praktyki.

W celu uzyskania informacji na temat miejsca i sposobu bezpiecznego dla środowiska recyklingu tego produktu użytkownicy w gospodarstwach domowych powinni skontaktować się z punktem sprzedaży detalicznej, w którym dokonali zakupu produktu, lub z organem władz lokalnych

Użytkownicy w firmach powinni skontaktować się ze swoim dostawcą sprawdzić warunki umowy zakupu. Produkt nie należy usuwać razem z innymi odpadami komercyjnymi.





UCH0142

Suport rabatabil de montare pe perete

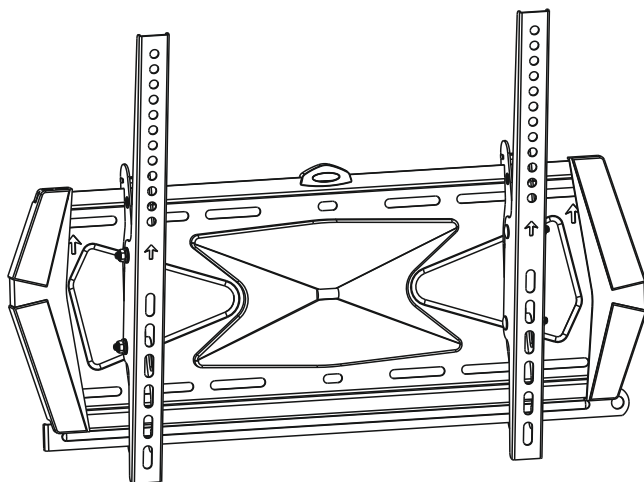

Manual de utilizare



300x300/400x200
400x400



English 1-10

Polski 11-20

Română 21-30

Deutsch 31-40

Inainte de instalare



- Nu incepeti instalarea suportului decat dupa ce ati citit si inteles instructiunile de montare.
- Respectati recomandarile din acest manual de instalare cu privire la distanta fata de perete necesara la montarea suportului.
- Instalarea suportului este recomandata sa fie executata de catre personal calificat.
- Verificati daca peretele este poate suporta sarcinile maxime admisibile de catre suport.
- Nu depasiti sarcina maxima admisibila a suportului.
- Asigurati-va ca suruburile de fixare pentru diblu sa fie centrate exact in mijlocul gaurilor de pozitionare de pe suport (eventual utilizati un dispozitiv de centrare) in momentul strangerii acestora.
- Strangeti suruburile ferm dar nu exagerati. Strangerea prea puternica a acestora poate distruge partile componente ale suportului
- Solicitati ajutorul altei persoane pentru pozitionarea aparatului pe suport.
- Suportul este destinat utilizarii in interior. Nu utilizati suportul in exterior pentru a evita riscul producerii de accidente sau defectarea produsului.

Continut colet

Asigurati-va ca ati primit toate componentele necesare montarii suportului inainte de instalarea acestuia, urmarind figurile urmatoare:

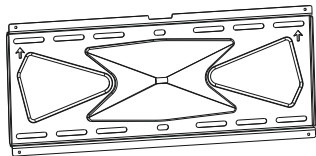

placa de baza (x1)
A



tija de siguranta (x1)
B

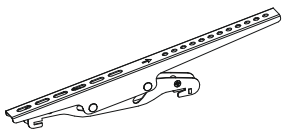

adaptor stanga (x1)
C

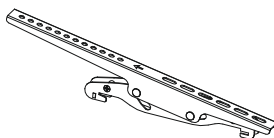

adaptor dreapta (x1)
D



nivela cu bula de aer (x1)
E



capac decorativ (x2)
F



ST2.9*6.5(x4)
G

Pachet M



M5x14 (x4)
M-A



M6x14 (x4)
M-B

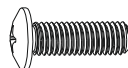

M8x20 (x4)
M-C



M6x30 (x4)
M-D



M8x30 (x4)
M-E



saiba (x4)
M-F



Saiba mica (x8)
M-G



Saiba mare (x4)
M-H

Pachet W

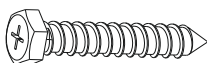

Surub ancorare ST6.3x55 (x4)
W-A



diblu beton (x4)
W-B



D6 saiba (x4)
W-C

1. Instalarea capacelor decorative

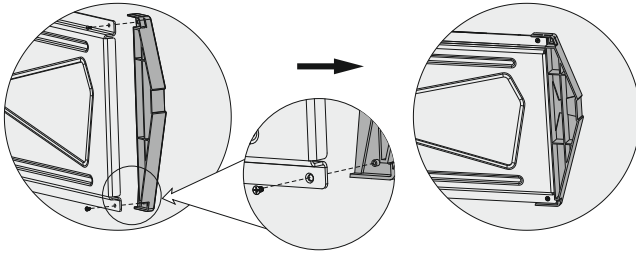

Fixati capacele decorative pe perete cu ajutorul suruburilor.
Nota: Gaurile capacelor decorative trebuie sa fie orientate in jos!

2a. Montarea suportului pe perete de lemn

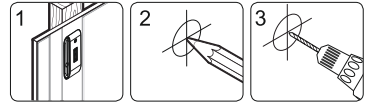
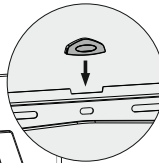
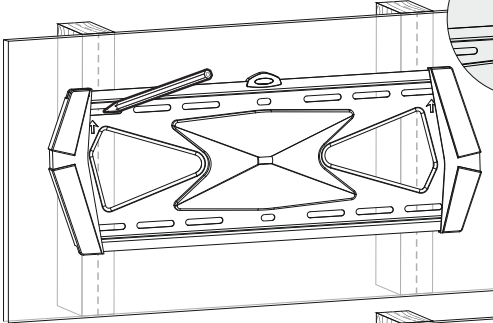
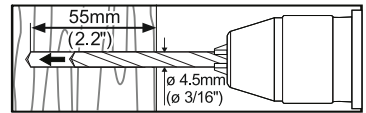
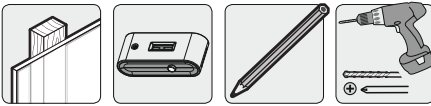

Gasiti si marcati locatia exacta a orificiilor de montare utilizand placa de baza ca sablon. Verificati intai ca aceasta sa fie orizontala, urmarind nivela cu bula de aer. Efectuati gaurile de montare

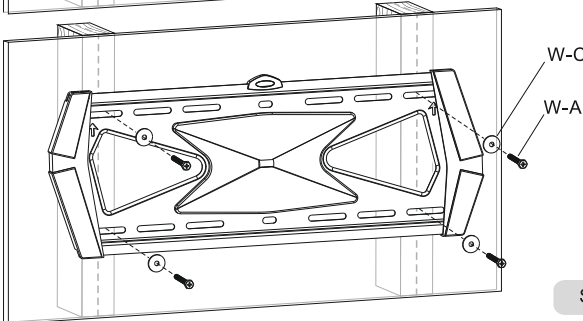
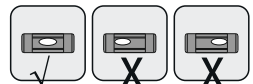

Insurubati placa de baza pe perete

Sageata de pe placa trebuie orientata in sus.

⚠ AVERTISMENT

- Asigurati-va ca suruburile de montare sunt bine pozitionate si stranse. Folosirea unui detector de metale este recomandata atunci cand efectuati gaurile de prindere.
- Cei care instaleaza sunt responsabili cu furnizarea de echipament pentru alte tipuri de situatii de montare.
- Instalatorii trebuie sa verifice ca suprafata de sprijin sa suporte in conditii de siguranta sarcina echipamentelor si toate componentele atasate..

2b. Montarea suportului pe perete de beton

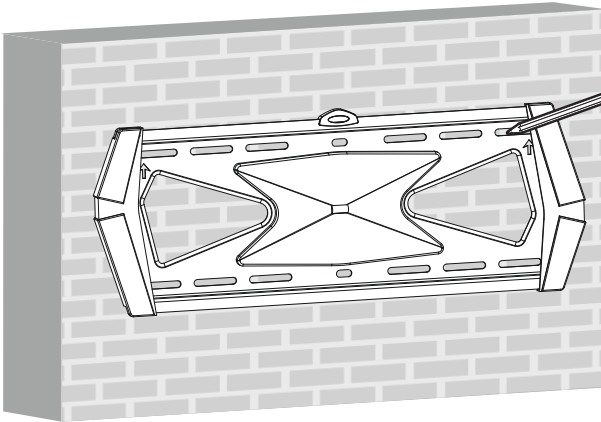
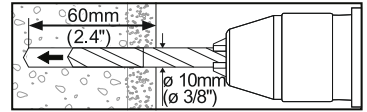

1
Marcati locatia exacta a orificiilor de montare

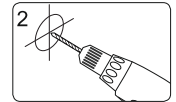

2
Efectuati gaurile de ghidare

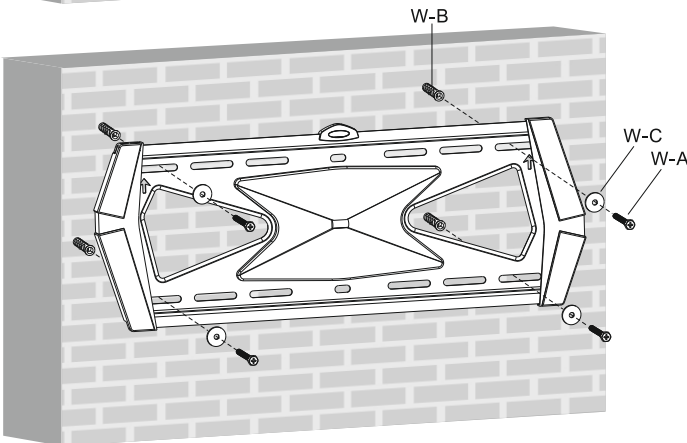
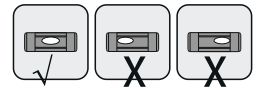

Insurubati placa de baza pe perete

Cu sageata de sus a placii in sus.

AVERTISMENT

- La instalarea suportului pe perete de beton, verificati ca grosimea betonului sa fie de cel putin 1-3/8" (35mm) pentru a putea folosi ancorele de beton. Asigurati-va ca montati pe o suprafata solida, in general lasand o distanta de 1" (25mm) fata de marginea peretelui de beton. Utilizati masina de gaurit cu atentie, pentru a evita spargerea peretelui atunci cand exista un spatiu gol sau o cavitate.
- Instalatorii trebuie sa verifice ca suprafata de sprijin va suporta in conditii de siguranta sarcina echipamentelor si toate componentele atasate.

3. Instalarea adaptoarelor pentru suport

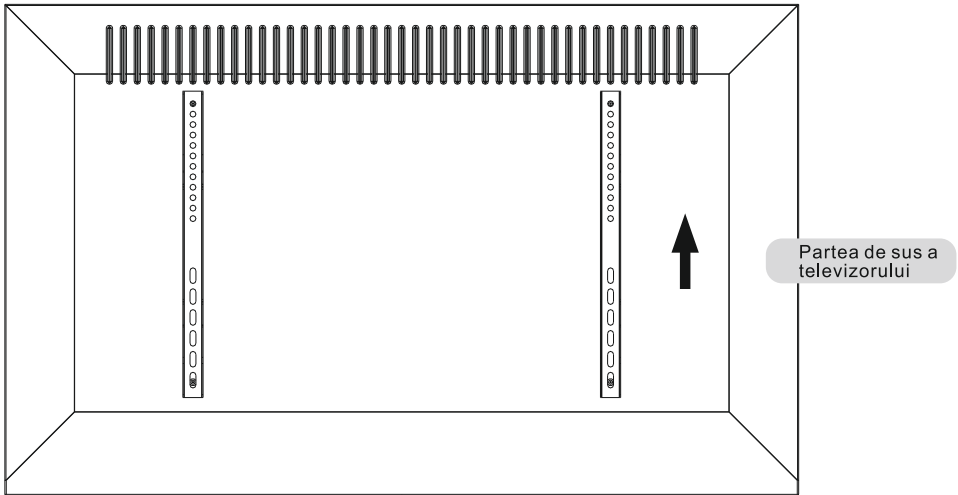

3-1 Pentru TV cu spatele drept (plat)

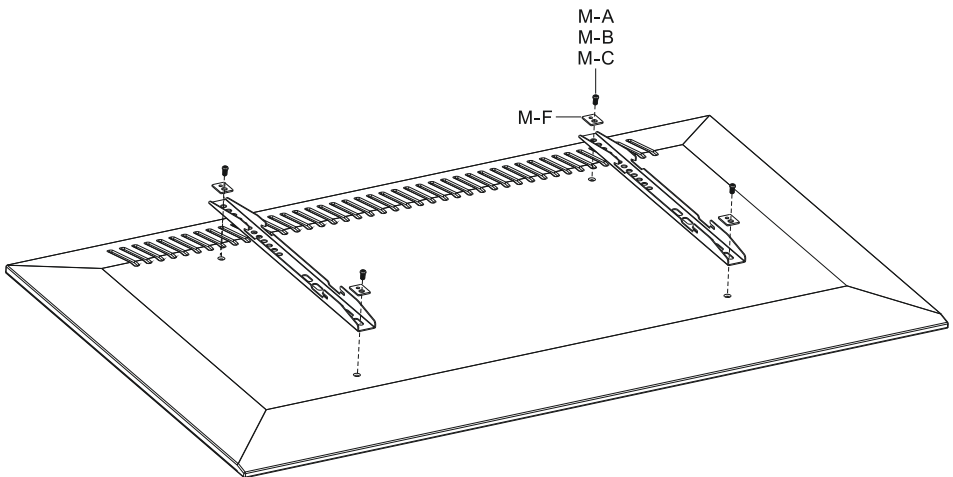

3-2 Pentru TV cu spatele curbat sau pentru accesarea intrarilor A/V

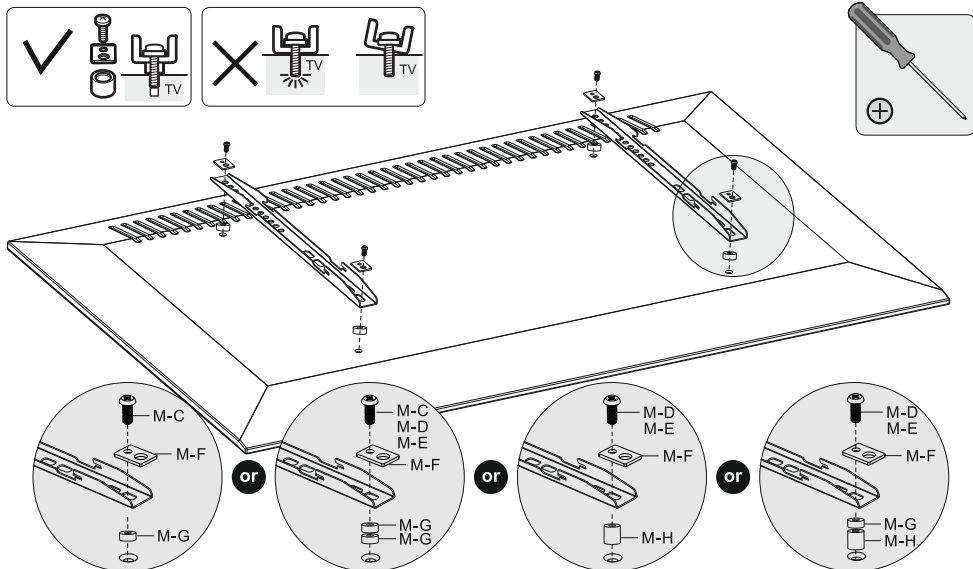

Nota: Alegeti suruburile, saibele si distantierele (daca e necesar) in functie de tipul ecranului.

- Pozitionati adaptoarele cat mai aproape de centrul ecranului.
- Insurubati adaptoarele pe TV.



Strangeti toate suruburile dar nu exagerati.

4. Montarea televizorului pe suport

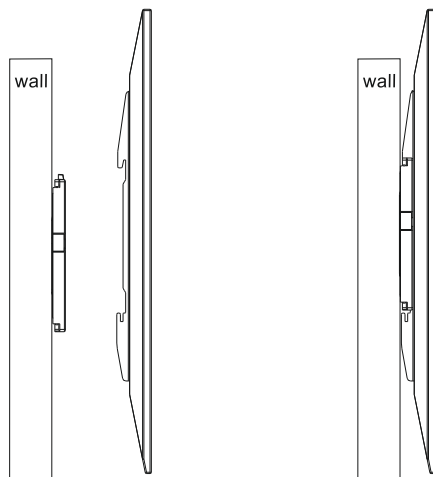

Prindeti televizorul pe partea de sus a placi de perete.

Important: Asigurati-va ca televizorul a fost montat corespunzator inainte de a-i da drumul.

5. Bara de siguranta

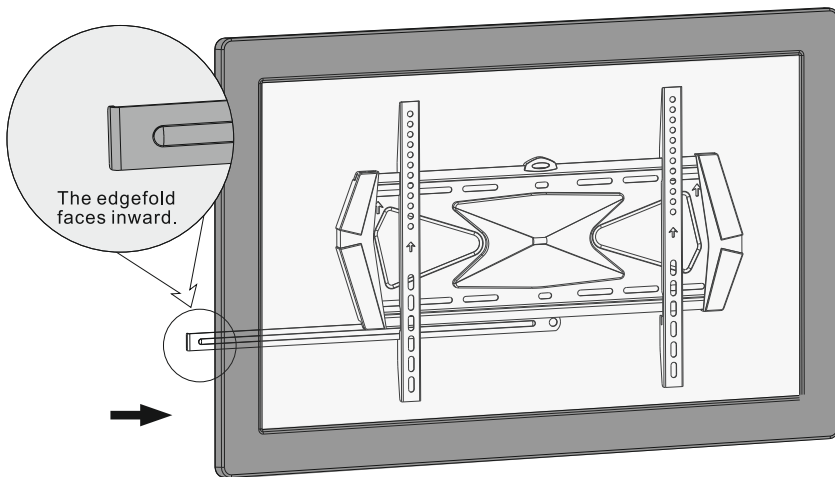

Introduceti bara de siguranta pentru a fixa sinele.

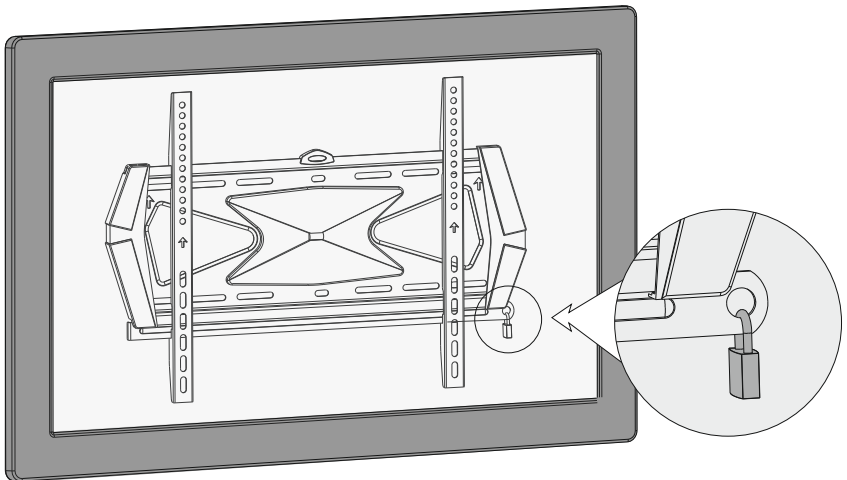

Folositi lacatul pentru a preveni un posibil furt al televizorului. (Lacatul nu este inclus)

5. Reglajul de inclinare

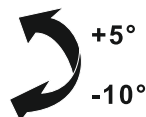
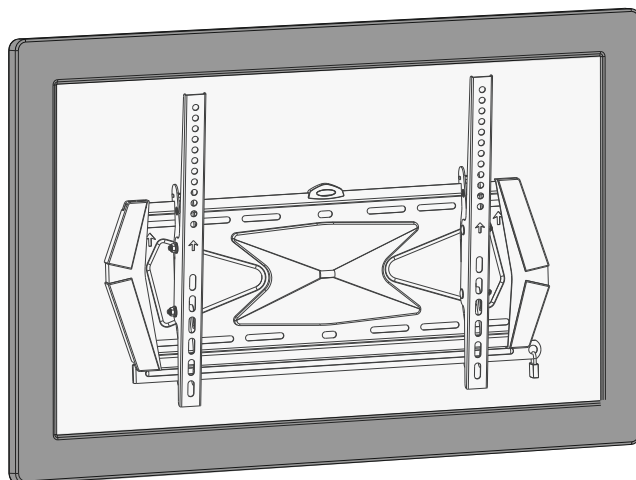

Intretinere

Intretinere

- Verificati ca suportul sa fie fixat la intervale regulate (cel puțin o data la 3 luni)
- Va rugam sa contactati furnizorul in cazul in care aveti intrebari.

Romania



Reciclarea corecta a acestui produs
(reziduuri provenind din aparatura electrica si electronica)

Marcajale de pe acest produs sau mentionate in instructiunile sale de folosire indica faptul ca produsul nu trebuie aruncat impreuna cu alte reziduuri din gospodarie atunci cand nu mai este in stare de functionare. Pentru a preveni posibile efecte daunatoare asupra mediului inconjurator sau a sanatatii oamenilor datorate evacuării necontrolate a reziduurilor, va rugam sa separati acest produs de alte tipuri de reziduuri si să-l reciclati in mod responsabil pentru a promova refolosirea resurselor materiale.

Utilizatorii casnici sunt rugati sa ia legatura fie cu distribuitorul de la care au achizitionat acest produs, fie cu autoritatile locale, pentru a primi informatii cu privire la locul si modul in care pot depozita acest produs in vederea reciclării sale ecologice.

Utilizatorii institutionali sunt rugati sa ia legatura cu furnizorul si sa verifice conditiile stipulate in contractul de vanzare. Acest produs nu trebuie amestecat cu alte reziduuri de natura comerciala.



Produs in RPC pentru Lechpol Electronic SRL, Republicii nr. 5, Resita, CS, ROMANIA.

UCH0142 Schwenkbare Wandhalterung

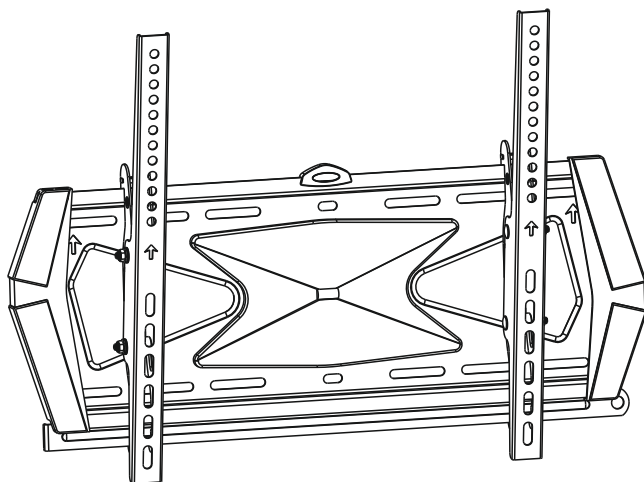

Bedienungsanleitung



300x300/400x200
400x400



47"
MAX



40kg
(88lbs)
MAX

English 1-10

Polski 11-20

Română 21-30

Deutsch 31-40

Vor Der Montage



- Beginnen Sie mit der Montage erst nachdem Sie die Montageanweisungen gelesen und verstanden haben.
- Befolgen Sie die Empfehlungen des Handbuchs bezüglich des benötigten Abstandes zwischen Wand und Halterung.
- Es wird empfohlen, die Montage von qualifiziertem Personal durchzuführen.
- Prüfen Sie, ob die Wand die Belastung der Halterung aushält.
- Überschreiten Sie nicht die maximal zulässige Last der Halterung.
- Bei einer Montage auf einer Holzwand achten Sie darauf, dass die Befestigungsschrauben in der Mitte der Pfosten zentriert werden (eventuell benutzen Sie eine Zentriervorrichtung).
- Ziehen Sie die Schrauben fest an, aber ziehen Sie die Schrauben nicht übermäßig an. Zu festes Anziehen der Schrauben, kann diese beschädigen und vermindert dadurch ihre Haltkraft.
- Bitten Sie eine andere Person um Hilfe für die Positionierung des Gerätes in der Halterung.
- Die Halterung ist nur für den Innenraum bestimmt. Verwenden Sie die Halterung nicht im Außenbereich um das Risiko von Verletzungen oder Beschädigungen am Produkt zu vermeiden.

Inhalt Der Packung

Vor der Montage Stellen Sie sicher, dass alle notwendigen Einzelteile vorhanden sind anhand folgender Abbildungen.

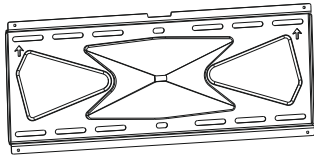

Basisplatte (x1)
A



Sicherheitsstange (x1)
B

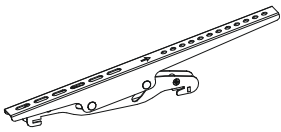

Halterung links (x1)
C

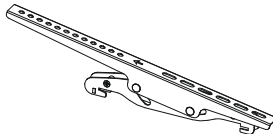

Halterung rechts (x1)
D



Wasserwaage (x1)
E



Dekorative Abdeckung (x2)
F



ST2.9*6.5(x4)
G

Paket M



M5x14 (x4)
M-A

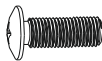

M6x14 (x4)
M-B



M8x20 (x4)
M-C



M6x30 (x4)
M-D



M8x30 (x4)
M-E



Scheibe (x4)
M-F



Kleines Distanzstück
(x8) M-G



Grosses Distanzstück
(x4) M-H

Paket W

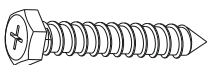

Holzschraube ST6.3x55 (x4)
W-A



Betondübel (x4)
W-B



D6 Scheibe (x4)
W-C

1. Montage der Dekorativen Abdeckung

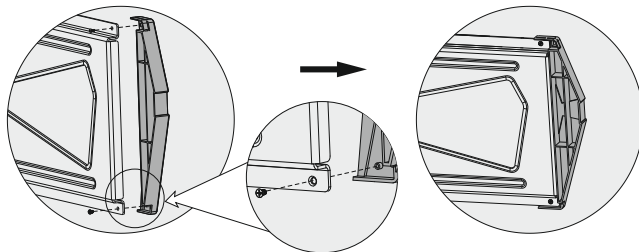

Montieren Sie die dekorative Abdeckung an der Wandplatte mit Hilfe von Schrauben
Hinweis: Mit dem Spalt der dekorativen Abdeckung nach unten.

2a. Montage An Einer Holzwand

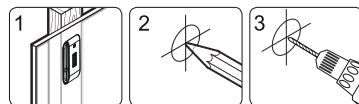
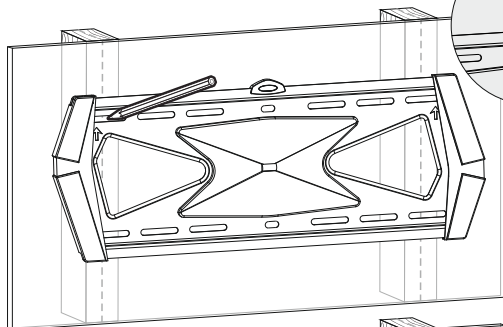
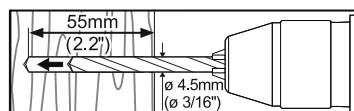

Finden und markieren Sie die exakte Position der Montagelöcher

Löcher vorbohren

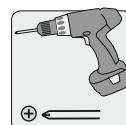
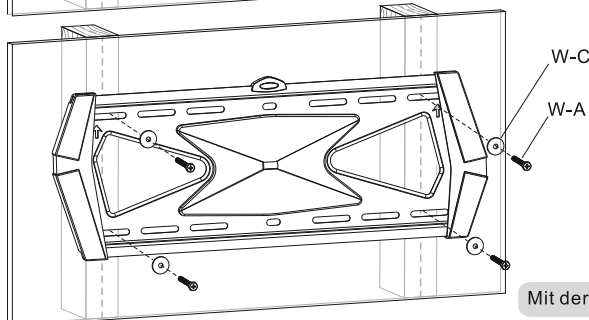
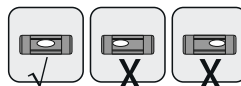

Schrauben Sie Wandplatte an die Wand

Mit der Platten-Markierung Pfeil nach oben aufwärts

⚠️ WARNUNG

- Stellen Sie sicher dass die Montageschrauben sich im Zentrum der Balken befinden. Benutzen eines Balkenfinders ist sehr empfehlenswert.
- Monteure sind verpflichtet Montagezubehör für andere Arten von Montagesituationen zu liefern.
- Monteure müssen die Tragfähigkeit der Montagefläche überprüfen, ob diese die gesamte Last der Geräte und angeschlossenes Zubehör sicher aushält.

2b. Montage Auf Vollziegel oder Betonwand

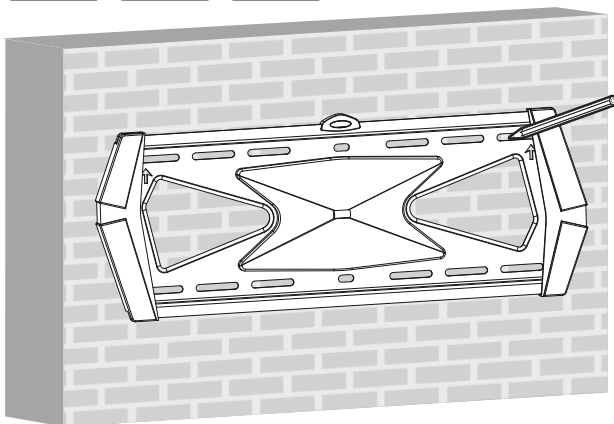
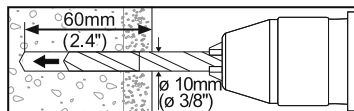

1
Finden und markieren Sie die exakte Position der Montagelöcher

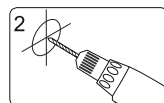

2
Löcher vorbohren

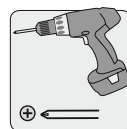
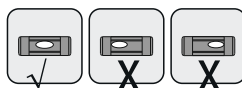
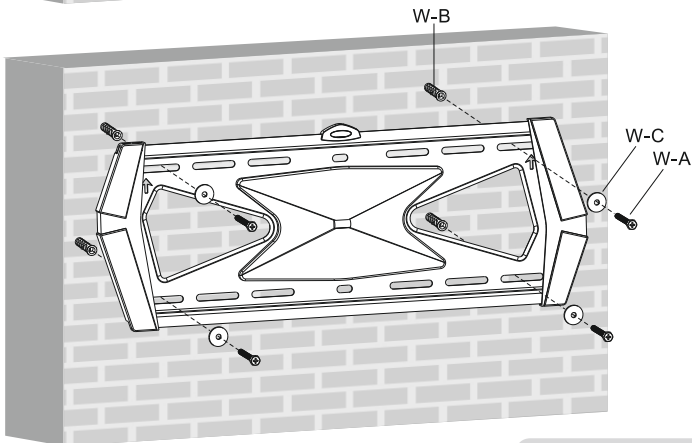

Schrauben Sie Wandplatte an die Wand

Mit der Platten-Markierung Pfeil nach oben aufwärts

WARNUNG

- Bei der Montage der Wandhalterung auf Betonblocks, überprüfen Sie ob die Betondicke 1-3/8" (35 mm) beträgt, um Betondübel zu benutzen. Bohren Sie nicht in die Mörtelverbindungen! Stellen Sie sicher dass die Montage in einem soliden teil des Betonblocks erfolgt, im Allgemeinen 1" (25 mm) Minimum vom Rand des Blocks. Es wird empfohlen, beim bohren der Löcher, die Bohrmaschine auf eine langsame Geschwindigkeit einzustellen anstelle des Schlagbohrers, um das Ausbrechen der Löcher zu vermeiden beim auftreffen auf einen Hohlraum.
- Monteure müssen die Tragfähigkeit der Montagefläche überprüfen, ob diese die gesamte Last der Geräte und angeschlossenes Zubehör sicher aushält.

3. Montage der Adapterklammern

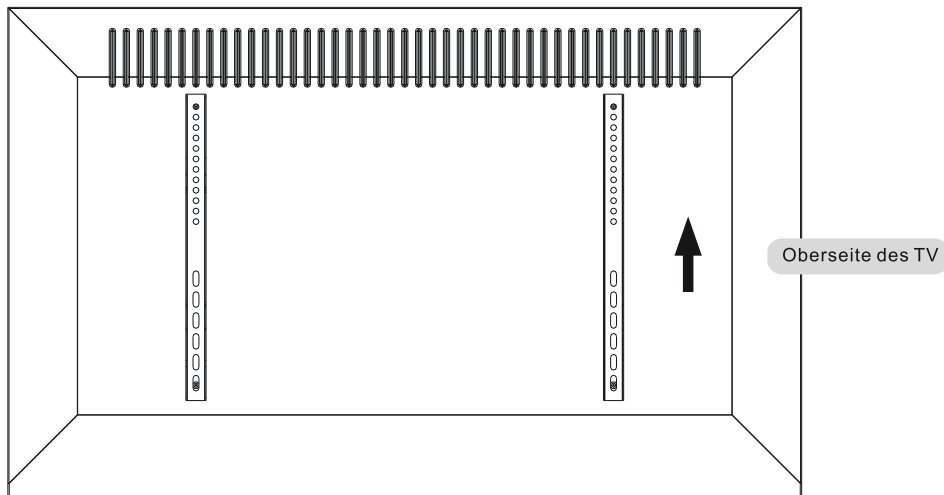

3-1 Für Fläche Hinterseite

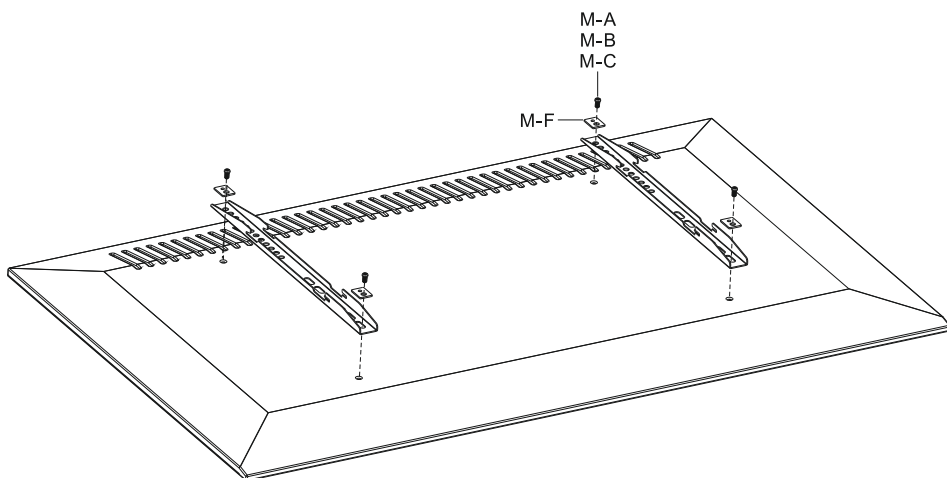

3-2 Für Zurückgesetzte Hinterseite oder Zugängliche A/V Eingänge

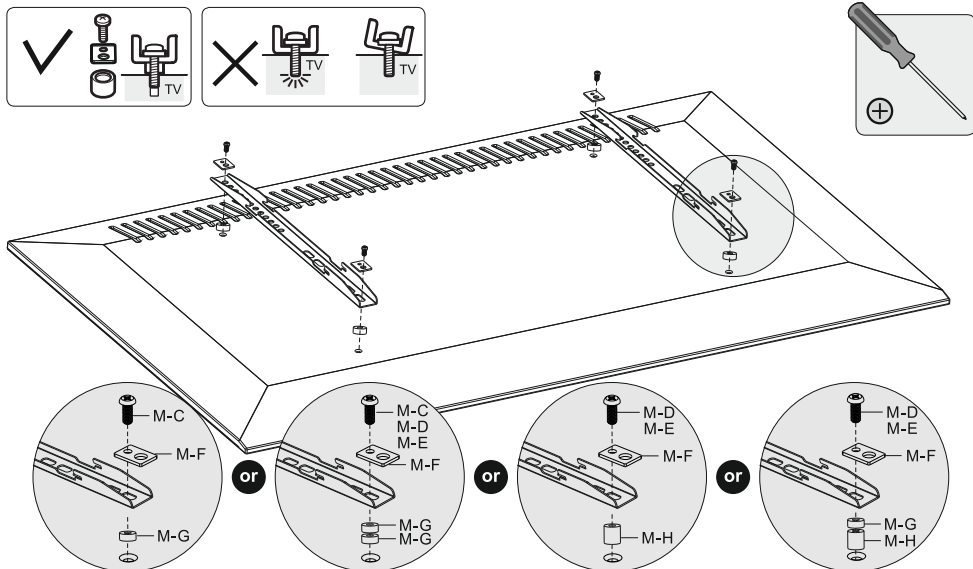

Hinweis: Wählen Sie passende Schrauben, Scheiben und Distanzstücke, (wenn nötig) passend zum Bildschirmtyp.

- Stellen Sie die Adapterklammern so nach wie möglich zum Zentrum des Bildschirms.
- Befestigen Sie die Adapterklammern mit Schrauben am Bildschirm.



Alle Schrauben fest anziehen, aber nicht überdrehen.

4. Bildschirm auf die Halterung Aufsetzen

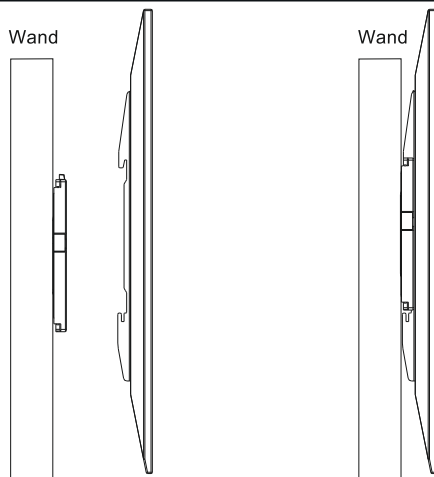

TV am oberen Teil der Wandplatte aufhängen.

Wichtig: Stellen Sie sicher dass der TV korrekt aufgehängt ist, bevor Sie das Gerät loslassen.

5. Sicherheitsstange

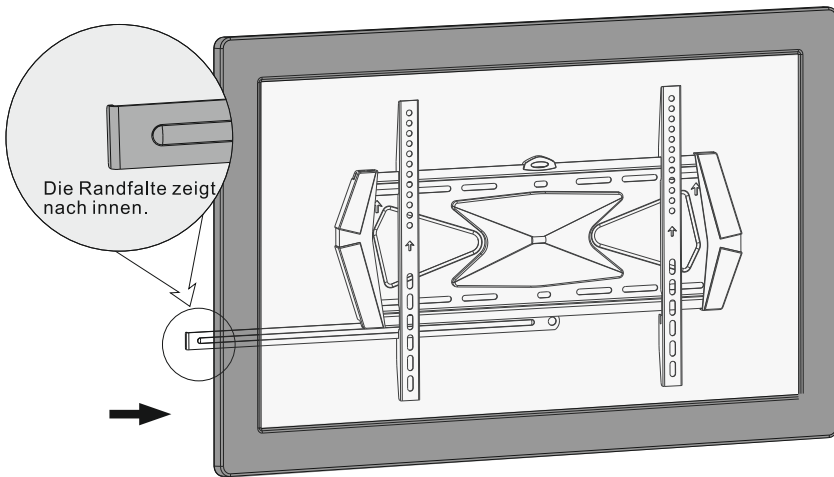

Sicherheitsstange einfügen um die Schienen zu sichern.

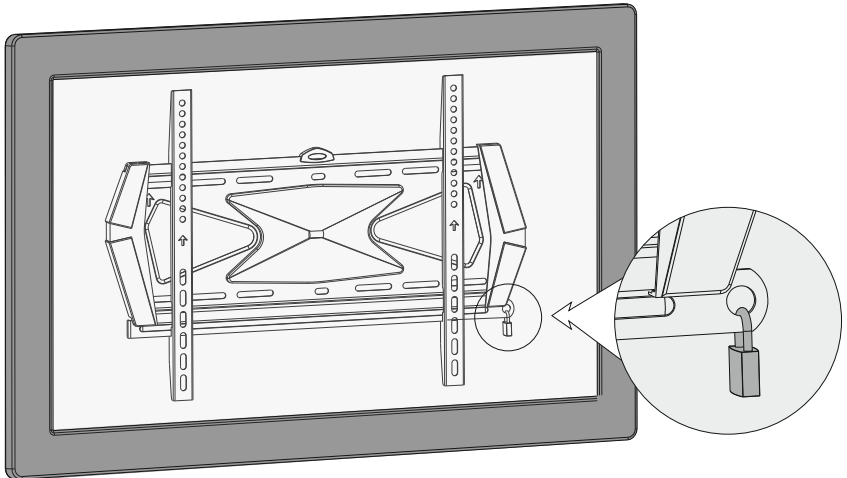

Benutzen Sie ein Schloss zur Diebstahlsicherung. (Schloss ist nicht im Lieferumfang)

5. Neigungswinkel Einstellen

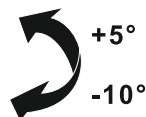
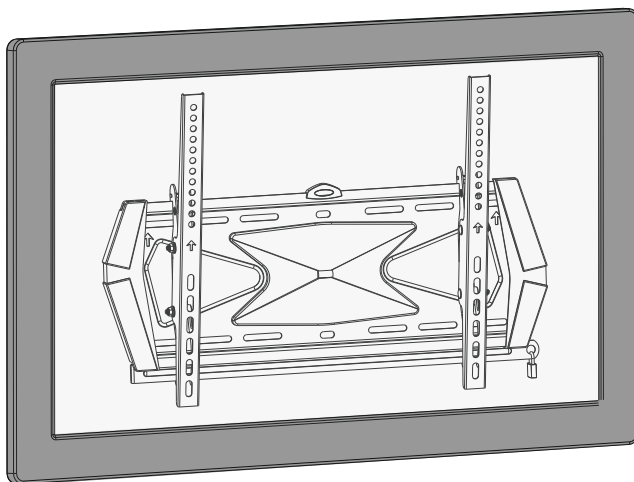

Wartung

Wartung

- Überprüfen Sie ob die Klammern sicher befestigt sind in regelmäßigen Abständen (zumindest alle drei Monate)
- Für etwaige Fragen wenden Sie sich an Ihren Händler.

Deutsch



Korrekte Entsorgung dieses Produkts (Elektromüll)

(Anzuwenden in den Ländern der Europäischen Union und anderen europäischen Ländern mit einem separaten Sammelsystem)

Die Kennzeichnung auf dem Produkt bzw. auf der dazugehörigen Literatur gibt an, dass es nach seiner Lebensdauer nicht zusammen mit dem normalen Haushaltsmüll entsorgt werden darf. Entsorgen Sie dieses Gerät bitte getrennt von anderen Abfällen, um der Umwelt bzw. der menschlichen Gesundheit nicht durch unkontrollierte Müllbeseitigung zu schaden. Recyceln Sie das Gerät, um die nachhaltige Wiederverwertung von stofflichen Ressourcen zu fördern

Private Nutzer sollten den Händler, bei dem das Produkt gekauft wurde, oder die zuständigen Behörden kontaktieren, um in Erfahrung zu bringen, wie sie das Gerät auf umweltfreundliche Weise recyceln können

Gewerbliche Nutzer sollten sich an Ihren Lieferanten wenden und die Bedingungen des Verkaufsvertrags konsultieren. Dieses Produkt darf nicht zusammen mit anderem Gewerbemüll entsorgt werden





www.cabletech.pl